



CD40030 WITH ICEO400

### Features

- Only 30" (762 mm) wide.
- Storage 180 lbs (81 kg) of ice per day.
- Turbo Dispense dispenses ¼ lbs of ice per second.
- Power Clean allows access to the bin for easy cleaning without moving the ice machine. Interlock safety switch turns off machine agitation when top-front access panel is removed.
- 4" (102 mm) foam insulation for maximum ice preservation —no more quick melting ice.
- Constructed from corrosion-resistant stainless steel and fingerprint-proof plastic.
- Great for hard water, food safety and tight spaces.
- Ultra-low profile design.
- Maximum ice storage in a minimum amount of space.
- User friendly push-to-dispense operation.
- Available with water glass filler

CD40030/40130/40530 CUBE ICE DISPENSER

### Options

Ice Machine Model	Water Dispenser
CD40030	No
CD40130	Included
CD 40530	N/A

### Ice Form



CUBE

Full Cube Dimensions	
W x D x H (in.)	7/8 x 7/8 x 7/8
W x D x H (mm)	22 x 22 x 22
Half Cube Dimensions	
W x D x H (in.)	3/8 x 7/8 x 7/8
W x D x H (mm)	10 x 22 x 22

ICE PRODUCTION FOR OPTIONAL CUBE ICE MAKERS—LBS. (KG) PER 24 HOURS*								
Model No.	ICE O250	ICE O305	ICE 400	ICE O405	ICE O406	ICE O500	ICE O606	ICE O605
Air-Cooled	336 (153)	361(164)	505 (230)	498 (226)	529 (240)	600 (273)	652 (296)	636 (289)
Water-Cooled	333 (151)	344 (155)	496 (225)	440 (200)	523 (237)	596 (271)	619(281)	609 (277)
Remote-Cooled	N/A	N/A	N/A	N/A	N/A	567 (258)	605 (275)	555 (252)
Voltage Char.	115/60/1	230/50/1	115/60/1	230/50/1	208-230/60/1	115/60/1	208-230/60/1	230/50/1

\*Tested at 70°F Air/50°F Water.  
All specifications and performance data are subject to normal manufacturing variances.



CD40030/40130/40530 CUBE ICE DISPENSER

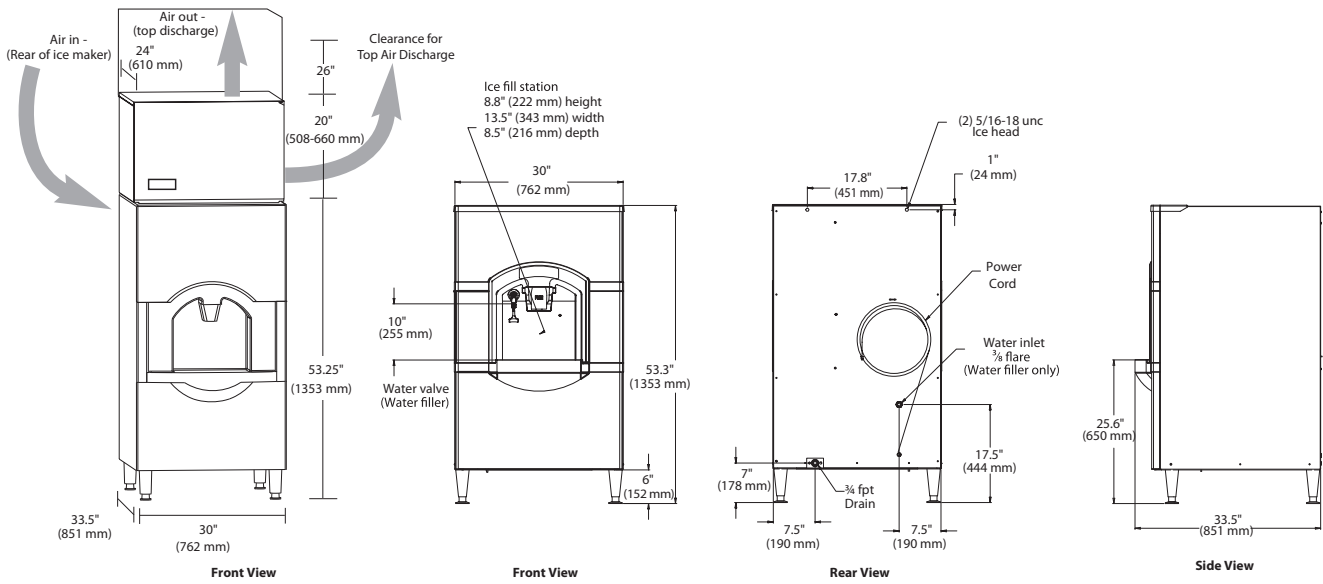

## Operating Requirements

	MINIMUM	MAXIMUM	
		60 Hz	50Hz
Ambient Temp. Range Air	50°F (10°C)	100°F (38°C)	110°F (43°C)
Water Temp.	40°F (4.4°C)		90°F (32°C)
Water Pressure	20 PSIG (1.4BAR)	60 PSIG (4.1BAR)	

## Dimensions (dispenser only)

ALL MODELS	
W x D x H (in.)	30 x 33.5 x 53.25
W x D x H (mm)	762 x 851 x 1353

## Specifications

Model Number	Dispenser Operation	ARI Bin Storage lbs (kg)	Voltage Characteristics	Min. Circuit Ampacity
CD40030	Push	180 (81)	115/60/1	2.1
CD40130	Push/Water			
CD40530	Push		230/50/1	

All specifications and performance data are subject to normal manufacturing variances.

- Note #1: Model CD40030, CD40130 and CD40530 dispensers accept all 30" (762 mm) ICE Series™ Cube Ice Makers. Do not use with ICE1506.
- Note #2: Water dispensers cannot be field-installed on the CD400 Series Dispensers.
- Note #3: CD40030 and CD40530 Series units do not require an Adaptor and Bin Level Kit. Not for use with 22" (559 mm) machines.

### NOTES:

Number of Wires: 3 (including ground)  
 Approx. Shipping Weight lbs (kg): CD40030 220 (100) • CD40130 224 (102) • CD40530 220 (100)  
 Cordset is included with the following models: CD40030 220 (100) • CD40130 224 (102)